



making waves in a
wire-free world

DataTrack

Versatile text
messaging System

features

- Compact unit ideal for retail, restaurants and hospitality
- Up to 20 pre-programmed keys for rapid, one-touch messaging
- Instant plug and play
- Can be wall or desk mounted
- Wipe clean keypad
- Coverage of 100,000 sq. ft.
+ with standard 1/4 wave aerial



The Scope DataTrack staff call system is THE system for the restaurant and hospitality trade. It provides a cost effective solution to a wide range of applications where individuals or groups need to be paged with a single button press. The transmitter can also be used to control a telemetry or telecommand receiver.

The units are housed in a compact wipe clean enclosure which can either be desk or wall mounted. A variety of keypads are available to suit the user's application.

DataTrack 14 Waiter Call

The Waiter Call model is specifically designed for restaurants, where the kitchen needs to alert waiters when meals are ready. The unit features a 14 way wipe clean keyboard with confirmation lights for each button. Simply write the name of the waiter beside any key with a non-permanent marker and a single button press from kitchen staff will alert waiters to the fact that a meal is ready and waiting to be served. This unit calls pager(s) that have been locked into vibrate mode for silent unobtrusive operation. This can be combined with a word prompt to confirm the location of the call e.g. kitchen, bar, cafe, etc. An escalating alert feature can also be used to warn chef or the manager if a meal is not collected within a given time frame. When the waiters collect the meals, they merely press their button again to confirm attendance, which cancels the LED on the panel. A x2 and x3 button feature is also provided which can initiate a different vibrate pattern and/or word prompt to direct the waiter(s) to a different location (e.g. Bar, Kitchen, Reception, etc).

The DataTrack 14 Waiter Call system is also available with a convenient separate Cancel Panel which can be located outside a kitchen serving hatch, enabling the waiter to cancel the call without the need to enter the kitchen itself.

DataTrack 20

The DataTrack 20 has seen tremendous success in retail outlets, where a unit can be installed at each check out and used to transmit up to 20 different pre-programmed messages directly to staff carrying pocket pagers. The messages and the keypad legends can be tailored to meet the customer's requirements.



DataTrack 14
Waiter Call

Track

Versatile text messaging System

For larger installations, a system controller can be utilised, which can receive transmissions from all DataTrack units and process the data before forwarding it to relevant pagers. Using the controller also has the advantage of allowing the system to be remotely programmed via its onboard modem.

For further information on the system controller (SCONLITE), please contact our technical sales team who will be pleased to assist you.

DataTrack 20 Insertable Legend

A host of applications exist where a one touch key press is desirable. DataTrack can initiate up to 20 different messages directly to staff carrying pocket pagers, or for example to control a telemetry or telecommand receiver. This transmitter is equipped with a special keypad featuring a slot for inserting a customised legend. This enables single units to be economically tailored to suit the customers' particular needs.

Demonstrating
insertable legend



Again, for larger systems a system controller can be utilised. This will allow the flexibility of being able to re-program the system when required and also provides on-board diagnostics for remote interrogation via modem.

Monitoring Receivers

A logging receiver can also be applied to any system, which will automatically monitor activity from any number of transmitters and output the data on a serial port. See separate receiver brochures for further details.

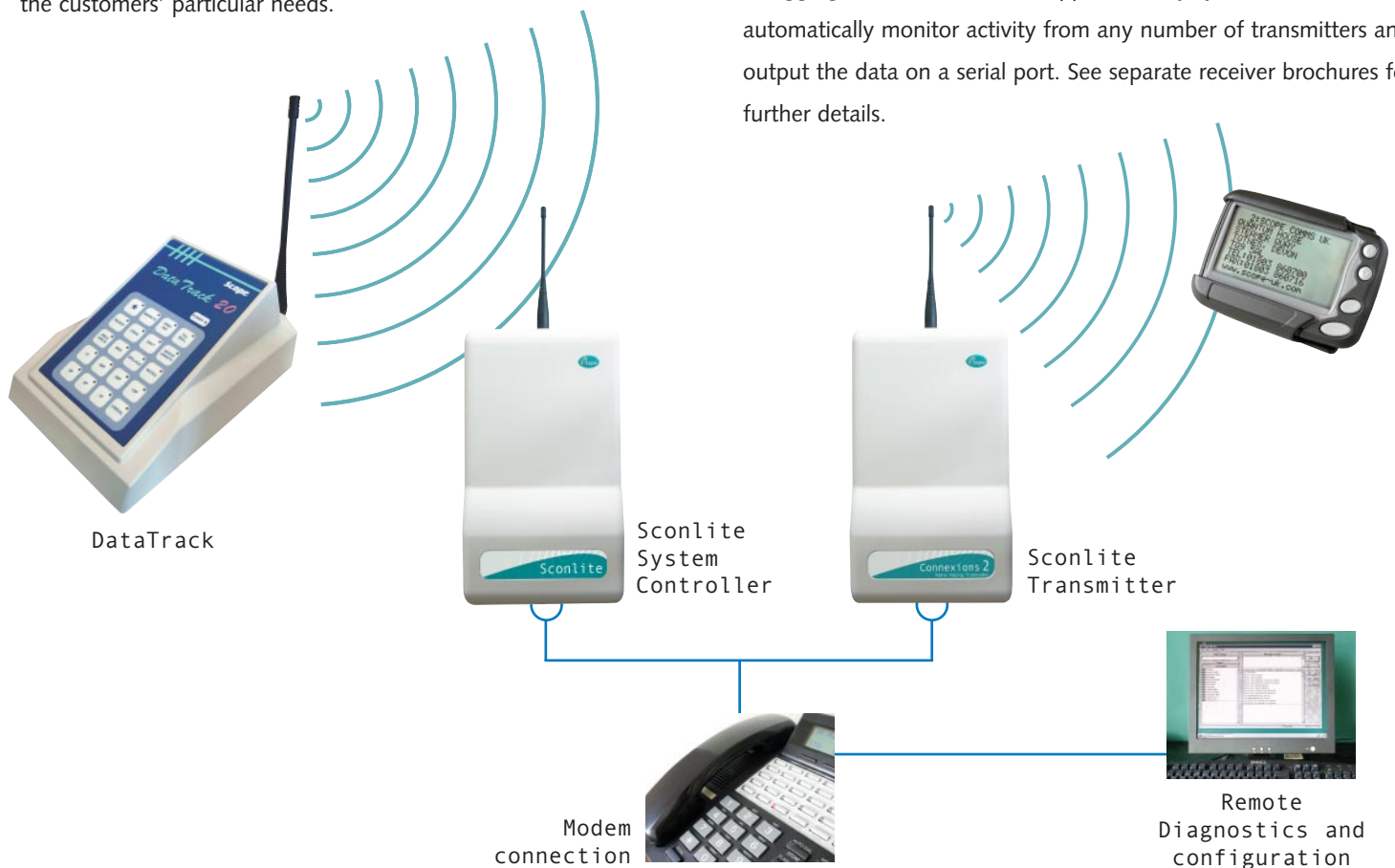

Versatile - one-touch - rapid text messaging system

Footprint: (H)* 90 x (W) 130 x (L) 220 mm
[*175mm with supplied antenna]

Power Input: 12V dc @ 0.5A (from Scope
Plugtop AC/DC Adaptor supplied)

Facilities required: 230V ac 13A mains
socket (square pin) within 1.5 metres
of unit.

Approvals: CE marked and compliant with
the R&TTE Directive 1999/5/EC.

Standards applied: EN 300 220 (SRD),
EN 300 224 (On-Site Radio Paging)
EN 301 489 (EMC) and EN 60950 (Safety).

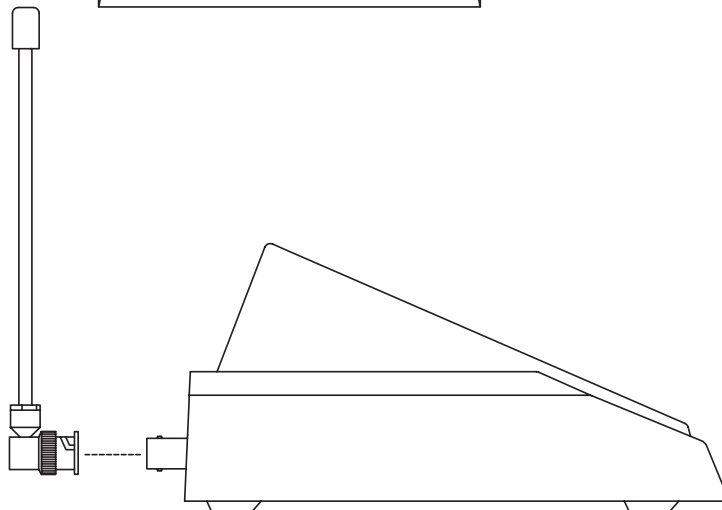
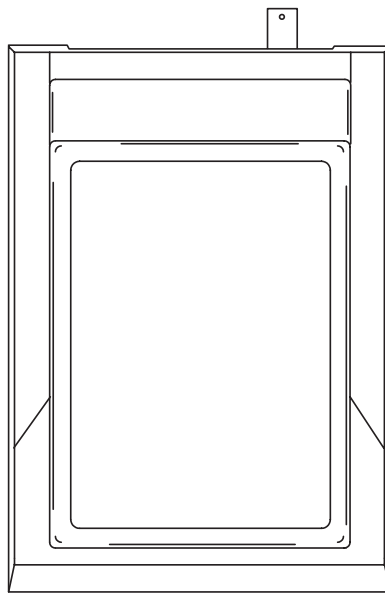
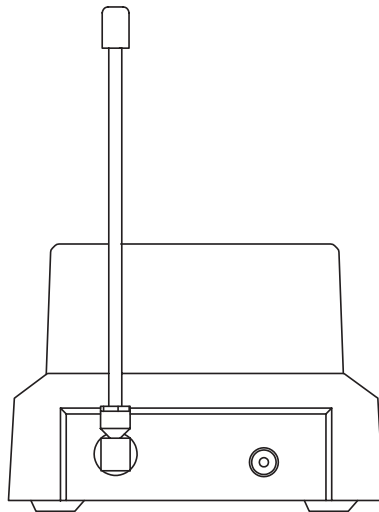

Programming and Product Related Services

A range of standard program settings are available from stock, together with a bespoke service for any specialised applications.

Other Special Requirements

We recognise that our customers are the driving force behind our business and our aim is to provide the most reliable, cost-effective and safe solutions to satisfy all their special requirements. Call us to find out how we can tailor a system to meet your individual needs.

Applications

- Retail/Supermarkets
- Casinos
- Restaurants
- Hospitality



Scope Communications UK Ltd
Quantum House
Steamer Quay
Totnes, Devon, TQ9 5AL
England

Tel: +44 (0)1803 860700
Fax: +44 (0)1803 863716
Website: www.scope-uk.com
Email: sales@scope-uk.com

Licensing: this equipment may require a license for operation in the UK.
Our sales team will provide details and the relevant forms.

© Scope Communications Uk Ltd. All specifications subject to change. E & OE.